



Industrial Digital Chart Recorder

Introducing the world's first Digital Chart Recorder with a 0.15% accuracy in multiple pressure ranges with customizable test reports in a lightweight yet rugged mobile weatherproof case.

Replace outdated mechanical chart recorders with today's technology at an affordable price. No more paper, pens, or batteries!

The Specialloy Digital Chart Recorder (SDCR) offers a rugged design against harsh environments with the ease of a Windows operating system. The Specialloy SDCR utilizes a Digital Pressure Transducer and has been designed to measure, analyze and record pressure directly on the mobile tablet without the need for costly I/O interface boards. It allows the user to measure up to 16 pressure & temperature inputs simultaneously and create customized test reports.



Features and Benefits

- Records and graphs pressure from vacuum to 72,000 PSI. Multiple Pressure ranges available.
- The SDCR allows the user to measure up to 16 pressure and temperature inputs simultaneously and create customized test reports.
- Easy setup, configuration and reporting. The software interface allows for real-time pressure and temperature recording using a 10" anti-glare touchscreen tablet.
- Easy Software Interface for Real-Time Pressure & Temperature Monitoring & Reporting
- Digital test report shareable via USB and wireless
- Bulkhead connections available in NPT or High Pressure.
- Light Weight Design (10 lbs.)
- 110 V Female Connection for standard Shop Power

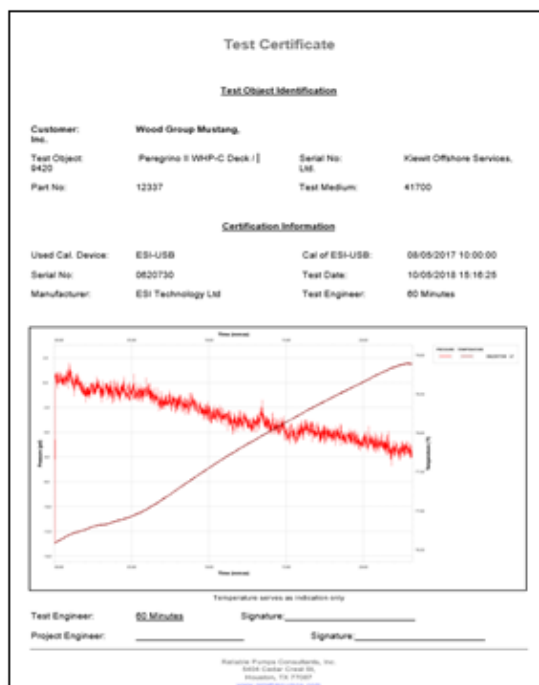

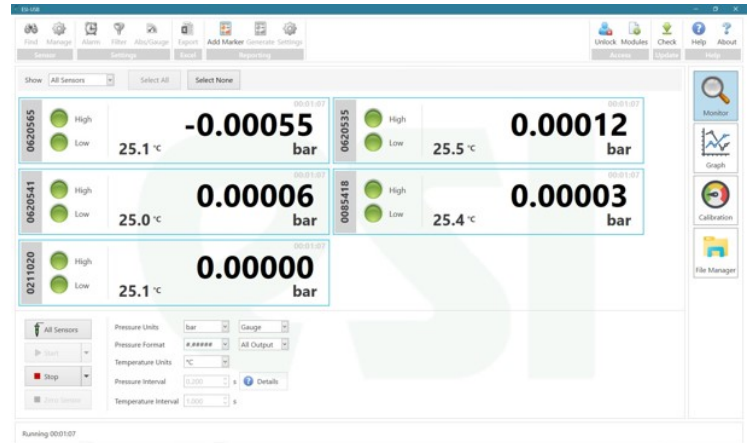

The transducer adjustable sample rate enables dynamic pressures to be measured with up to 21 bit resolution at user selectable speeds up to 1,000 Hz. For real-time analysis, data transferred to the PC is achieved without loss of accuracy or bandwidth. Data can be displayed in graphical or tabular form, with a choice of pressure units and fully adjustable scales. Data can be saved to a file or exported to Excel/PDF. The unique Silicon-on-Sapphire sensor technology provides outstanding performance and gives excellent stability over a wide temperature range. Excellent measurement accuracy provides high resolution with a precision greater than 1 in 10,000.

TYPE	SDCR-XX
Sensor Technology:	Silicone-on-Sapphire
Windows Tablet	10.1" Display with Touchscreen Interface
Standard Pressure Ranges:	<ul style="list-style-type: none"> • 0 to 1,500 PSI • 0 to 6,000 PSI • 0 to 15,000 PSI • 0 to 21,500 PSI • 0 to 30,000 PSI • 0 to 60,000 PSI • 0 to 72,000 PSI
Overpressure Safety:	2x up to 6,000 PSI; 1.5x for 15,000 PSI; 1.1x for 21,500 PSI; 1.5x for 30,000 PSI; 1.25x for 60,000 PSI+
Other Pressure Ranges:	PSI, bar, mBar, MPa, Pa, mH2O, mmHg, atm, kg/cm2, kPa
Accuracy NLHR:	≤ ± 0.15% of span BFSL
Temperature Ranges:	°F or °C
Operating Ambient Temperature:	32°F to +115°F
Storage Temperature:	-4°F to +140°F
Temperature Effects:	±1.5 %FS total error band for -14°F to +176°F. Typical thermal zero and span coefficients ±0.015 %FS/ °C
Pressure Media:	All fluids compatible with Stainless Steel (¼" NPT) or Titanium Alloy (¼" HPF)
Wetted Parts:	¼" NPT – Stainless Steel 316 ¼" HPF – Titanium Alloy
Pressure Connection:	¼" NPT or ¼" High Pressure Female (¼" HPF) / F250C

Suitable for use on all Hydrorex pressure test equipment series



Hydrorex / Specialloy digital chart recorders are the industry standard for accurate, reliable measurement and recording of pressure, differential pressure and temperature in a variety of applications

Dimensions

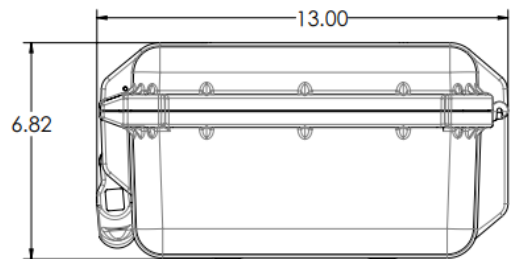
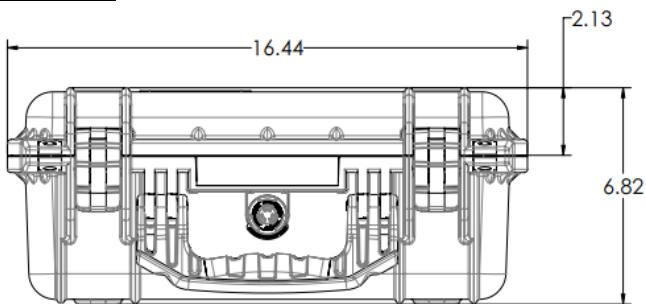

Optional Items

- Secondary Pressure Transducer
- Battery Life Extender
- Pipe Mount
- Upgraded Tablet Features
- External Display Adapters

